

DATA SHEET

5130



Ciena's 5130 Router is purpose-built for 5G networks that converge 4G/5G fronthaul, midhaul, and backhaul (xHaul) networks onto a common, simpler infrastructure. With dense 1/10/25GbE to 100GbE aggregation and support for both hard network slicing (FlexEthernet) and soft network slicing (Segment Routing), the 5130 is the ideal platform to simplify and de-risk the unique 4G to 5G journeys of mobile and wholesale operators.

The industry drives toward converged xHaul transport networks

Continued annual growth in 4G and 5G Radio Access Network (RAN) bandwidth demand is driving a change in the mix of connections and services, from 1GbE aggregation to 10GbE, and 10/25GbE aggregation to 100GbE. This ongoing growth will continue as network operators, mobile, and wholesalers, embark on their unique 4G to 5G journeys—resulting in substantial upgrades to their xHaul networks—and as traditional Mobile Network Operators (MNOs) modernize their transport networks to support the vastly improved end-to-end performance that is the promise of 5G. One key aspect of 5G networks, besides the substantial improvements in capacity and latency, is the decoupling of the Remote Radio Unit (RRU)—also referred to as Remote Radio Head (RRH)—from the Baseband Unit (BBU) in a mobile macro cell, which results in a fronthaul transport network between the RRU and the centralized BBUs that will then be virtualized, using Commercial Off-The-Shelf (COTS) servers. This new architecture is referred to as Centralized/Cloud (C-RAN). The BBU itself will be further disaggregated into a Centralized Unit (CU) and Distributed Unit (DU), which results in a midhaul transport network between them. By converging 4G/5G fronthaul, 5G midhaul, and 4G/5G backhaul, network infrastructure cost and complexity are optimized.

Features and benefits

- Temperature-hardened (-40°C to +65°C) with 9.9"/252mm depth for temperature-challenged or space-constrained locations
- 12 x 1/10/25GbE and 2 x 100 GbE fixed ports
- L1/L2/L3 low-latency switching
- Service isolation using FlexEthernet (FlexE)
- Carrier Ethernet, IP routing, SR-MPLS, and SRv6
- Hardware-assisted packet OAM scaled to deliver up to 25GbE services with guaranteed SLA differentiation
- Secure Zero-Touch Provisioning (SZTP) for rapid, secure, and error-free turn-up of services
- Advanced synchronization, including built-in GNSS receiver
- Built-in RFC 2544 and ITU-T Y.1564 SAT with 100 Gb/s traffic generation and analysis
- SDN ready next generation management including support for protocols such as NETCONF/YANG and gNMI/gRPC
- Ciena's MCP multi-layer support for end-to-end network management control and planning
- Redundant AC or DC power

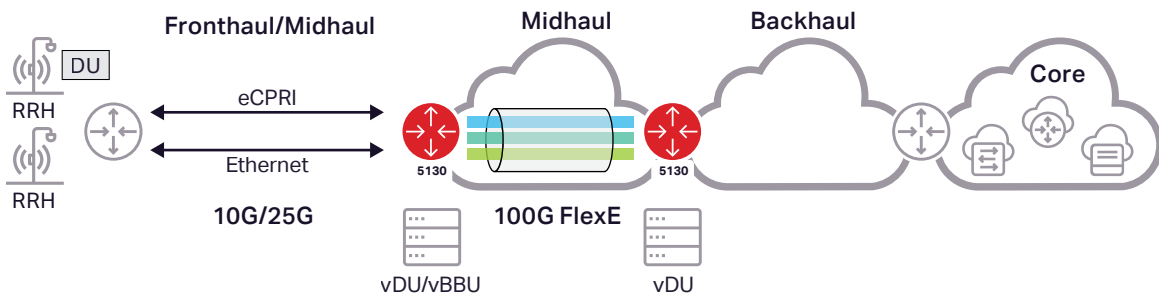

Figure 1. Cloud-RAN network application

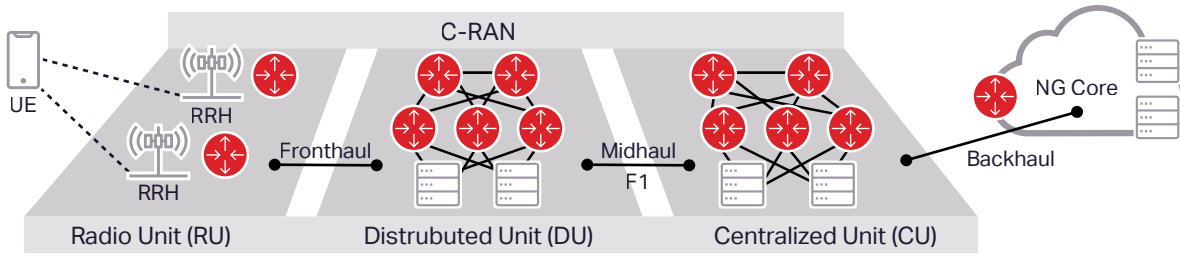

Figure 2. 5G NR RAN architecture

C-RAN enables significant reductions in power consumption, footprint, and complexity deployed at 4G/5G cell sites. The Common Public Radio Interface (CPRI) for 4G LTE C-RAN is highly inefficient from a fronthaul bandwidth perspective. For 5G NR RAN, available capacity will be significantly higher than 4G LTE, particularly with High Order Multiple-Input Multiple-Output (MIMO) antenna deployments. Several sub-layers of the 5G NR RAN functions will be decomposed and virtualized over x86 COTS servers, which will have a major impact on the required xHaul network performance to deliver upon the full promise of 5G.

5G NR RAN

As MNOs upgrade to a 5G NR RAN network, shown in Figure 2, changes in the User Equipment (UE, more commonly referred to as a mobile smartphone or handset), RAN, and mobile core are required. 5G brings the need to deliver higher capacity over the mobile network, driving the change in mix of wireline technology, performance, and services required in the access network from 1GbE to 10GbE, and increasingly from 10GbE to 25GbE—all requiring aggregation up to 100GbE. Additionally, the need to reduce latency for new applications like Augmented Reality (AR), Virtual Reality (VR), mobile gaming, and the growing IoT space will require ultra-reliable Low-Latency Communications (urLLC) and network slicing capabilities.

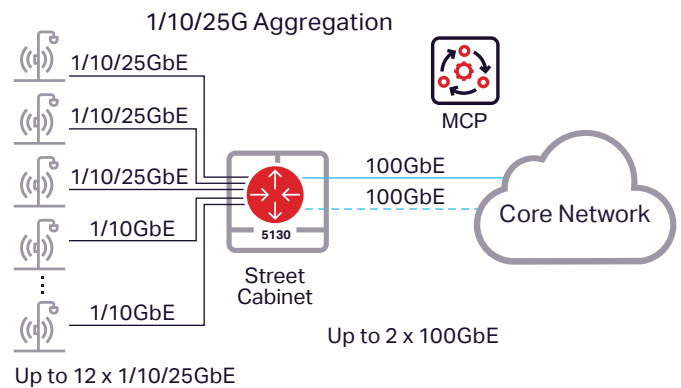

Figure 3. 5130 Router outside service and aggregation

All of these new technology and associated performance requirements—and support for existing 4G RAN networks as well—are supported by Ciena's 5130 Router.

Dense, compact form-factor platform

Efficient use of real estate assets is a growing concern for MNOs, who either host their own network equipment or lease power, space, and connectivity from wholesale providers. As services multiply, MNOs must choose between stacking 10G xHaul-capable equipment and new 5G NR RAN equipment, which will incur additional collocation costs. The 5130's sleek, shallow depth and front access enable and facilitate cabinet and controlled

environmental vault deployment. Extended temperature range support allows for installations in uncontrolled environments for outdoor aggregation of 1/10/25GbE, enabling high capacity at the outdoor edge for both 4G and 5G connectivity.

Space is increasingly limited and expensive, and network operators face substantial capital expenditures to activate new locations or must retire active equipment to free space for new service delivery. Addressing bandwidth demand growth by deploying more and larger equipment is simply not a sustainable business model—economically or environmentally. Ciena's 5130 cost-effectively offers dense 25GbE service delivery in a 1RU, 252mm deep, fixed form factor with dual power supplies and a variety of pluggable optics to minimize network downtime.

Fine-grained SLA monitoring and enforcement

The 5130 includes performance benchmark testing based on ITU-T Y.1564 and RFC 2544, enabling end-to-end 1/10/25G line-rate traffic measurements across virtual circuits. This approach improves end-customer satisfaction by enabling operations personnel to proactively respond to network events via increased performance visibility for differentiated Service Level Agreement (SLA) reporting.

Programmable midhaul gateway

As MNOs look for the ability to derive new revenue streams, the 5130 eCPRI/Ethernet-capable interfaces can be used to provide guaranteed SLA-based 5G services, made possible by network slicing and the underlying programmable wireline infrastructure that supports it, for new use cases and revenues—which is different from existing best-effort 4G LTE-centric mobile network services.

FlexE can be used to mitigate latency impacts in the midhaul when utilizing a midhaul gateway or transparently transporting traffic from a fronthaul gateway. Flex Ethernet (FlexE), standardized in the OIF, supports channelization as one of its use cases. Figure 3 shows that multiple traffic types (eCPRI, RoE, wireline services) can be carried using a FlexE channels over a 100 Gb/s FlexE link. The 5130 optimizes bandwidth and provides deterministic low-latency transport with FlexE. By mapping traffic into one of these channels with dedicated TDM-like scheduling, its latency and jitter will not be impacted by traffic in the other channel and bounded low-latency delivery can be ensured.

Advanced multi-layer protocol support

The 5130 supports a flexible selection of service offerings, including L2 and L3 services over a carrier-class, connection-oriented infrastructure using MPLS and Segment Routing.

The platform supports a rich suite of L2/L3 features with Ethernet, MPLS, MPLS LDP, Seamless MPLS, OAM, Sync, ACL, QoS, TACACS+ RADIUS, streaming telemetry, NETCONG/YANG, IGP (IS-IS, OSPF), ISIS-SR, BGP/MP-BGP, FlexEthernet, LAG, Network Slicing, FRR, SR, TI-LFA, and Segment Routing functionality.

The 5130 operates as a full-featured IP router supporting NETCONF/YANG to easily integrate into an open SDN environment with full visibility via streaming telemetry, and automated provisioning using open APIs.

Synchronization and timing

To realize the full benefit of 5G, highly accurate time/phase synchronization in addition to frequency synchronization, and even more stringent timing precision will be required. In the more latency-sensitive fronthaul network, care must be taken to deliver the required performance, especially in situations where traffic from 4G and 5G RRH is mixed. As eCPRI was defined to utilize a native packet transport, it is somewhat more tolerant to jitter than CPRI, which is natively a time domain-oriented constant bitstream. New technologies, such as FlexE and Time Sensitive Networking (TSN), have emerged as tools to provide these latency and jitter guarantees.

The 5130's rich timing and synchronization options including support to IEEE 1588v2 and Global Navigation Satellite System (GNSS) receiver enable new capabilities, such as Sync-as-a-Service with SLA for wholesale providers, hard and soft network slicing, as well as additional applications like massive Machine-Time Communication (mMTC), urLLC, and native Ethernet services in the wireless domain via 5G NRs.

The cost-effectiveness and versatility of the 5130 Router with xHaul network slicing provides synchronization and timing for C-RAN architectures with support for eCPRI/Ethernet, Adaptive IP™, and high density 1/10/25GbE to 100GbE aggregation.

Differentiation through accelerated service velocity

Service velocity has become a critical competitive advantage for network operators, mobile, and wholesalers. In many cases, service velocity is

the determining factor in winning new service opportunities. The 5130 implements Ciena's unique SZTP capabilities, allowing operators to deploy new packet-based services rapidly and securely in a fully automated manner. By reducing or eliminating costly and time-consuming manual intervention, provisioning errors are eliminated via SZTP. Most importantly, SZTP improves service deployment velocity and significant competitive advantage.

Rich packet Operations, Administration, and Maintenance (OAM) suite of capabilities

As network operators and their customers increasingly rely on new packet-based networks, providers must maintain guaranteed service levels. Packet networks must support a broad array of packet OAM capabilities to ensure operators can proactively and reactively maintain and report on the ongoing health of their networks and delivered services. The 5130 also supports a comprehensive set of hardware-assisted packet OAM capabilities, and is architected to provide SLA metrics and OAM at a high scale.

This enables operators to take full advantage of the port density and 360 Gb/s fabric for delivering the maximum number of services at the lowest cost. Additionally, the 5130 has an embedded line-rate Service Activation Test (SAT) engine (RFC 2544, ITU-T Y.1564), with traffic generation to a full 100 Gb/s to guarantee strict, market-differentiating SLAs, without relying on costly external test equipment and the highly trained personnel that requires.

Simplified multi-layer management and control

Ciena's Manage, Control and Plan (MCP) domain controller software offers a unique and comprehensive solution for the administration of mission-critical networks that span access, metro, and core domains, and provides unprecedented multi-layer visibility from the photonic to the packet layers. With this innovative management approach, MCP supports a programmable and automatable solution that provides a fully open approach to installing, manipulating, and monitoring service behaviors in an SDN environment.

Technical Information

Interfaces

Ethernet Ports

- 12 x 1GbE/10GbE/25GbE SFP28 ports
- 2 x 100GbE QSFP28 Ports
- OIF FlexEthernet (Flex) Implementation Agreement v1.1 and v2.0

Other

- 1 x USB-C Off-switch memory
- 1 x USB-C Console
- 1 x RJ45 Time-of-Day (ToD)
- 1 x SMB Phase input (1 pps in/out)
- 1 x SMB GNSS antenna
- 1 x RJ45 Management (MGMT)

Ethernet

- IEEE 802.1ad Provider Bridging (Q-in-Q) VLAN full S-VLAN range
- IEEE 802.1D MAC Bridges
- IEEE 802.1p Class of Service (CoS) prioritization
- IEEE 802.1Q VLANs
- IEEE 802.3 Ethernet
- IEEE 802.3ab 1000Base-T via copper SFP
- IEEE 802.3ad Link Aggregation Control Protocol (LACP)
- IEEE 802.3ba-2010 100Gb/s
- IEEE 802.3by-2016 25Gb/s
- IEEE 802.3z Gigabit Ethernet
- Layer 2 Control Frame Tunneling
- Link Aggregation (LAG): Active/Active; Active/ Standby
- Jumbo frames to 9216 bytes
- VLAN tunneling (Q-in-Q) for Transparent LAN Services (TLS)

Carrier Ethernet OAM

- EVC Ping (IPv4)
- IEEE 802.1ab Link Layer Discovery Protocol (LLDP)
- IEEE 802.1ag Connectivity Fault Management (CFM)
- IEEE 802.3ah EFM Link-fault OAM
- ITU-T Y.1731 Performance Monitoring

Synchronization

- External Timing Interfaces
 - ITU-T G.703 Frequency in or out (2.048MHz, and 10MHz)
 - ITU-T G.703 1pps and ToD in or out
- Integrated GNSS receiver
- ITU-T G.8262/G.8264 EED option1 and option2
- ITU-T G.8275.1 full timing support T-GM, T-BC and T-TSC
- G.8275.2 clock, Class C*
- Stratum 3E oscillator

Networking Protocols

- ISO10598 IS-IS intra-domain routing protocol
- OSPF Segment Routing extension
- OSPF TI-LFA Topology Independent Fast Reroute using Segment Routing
- RFC1195 Use of OSI Is-Is for Routing in TCP/IP and Dual Environments
- RFC1997 BGP Community Attribute
- RFC2328 OSPF Version 2
- BGP Prefix Independent Convergence
- EVPN FXC draft-ietf-bess-evpn-vpws-fxc-03.txt
- RFC2698 A Two Rate Three Color Marker
- RFC2865 Remote Authentication Dial in User Service (RADIUS)
- RFC3031 Multiprotocol Label Switching Architecture
- RFC3032 MPLS label stack encoding
- RFC3107 Support BGP carry Label for MPLS
- RFC4271 A Border Gateway Protocol 4 (BGP-4)
- RFC4360 BGP Extended Communities Attribute
- RFC4364 BGP/MPLS IP Virtual Private Networks (VPNs)
- RFC4456 BGP Route Reflection: An Alternative to Full Mesh Internal BGP (IBGP)

- RFC4632 Classless Inter-domain Routing (CIDR): The Internet Address Assignment and Aggregation Plan
- RFC4760 Multiprotocol Extensions for BGP-4
- RFC4762 Virtual Private LAN Service (VPLS) Using Label Distribution Protocol (LDP) Signaling (HVPLS)
- RFC5004 Avoid BGP Best Path Transitions from One External to Another
- RFC5036 LDP Specification
- RFC5037 Experience with the LDP protocol
- RFC5301 Dynamic Hostname Exchange Mechanism for IS-IS
- RFC5302 Domain-Wide Prefix Distribution with Two-Level IS-IS
- RFC5303 Three-Way Handshake for IS-IS Point-to-Point Adjacencies
- RFC5309 Point-to-Point Operation over LAN in Link State Routing Protocols
- RFC5396 Textual Representation of Autonomous System (AS) Numbers
- RFC5398 Autonomous System (AS) Number Reservation for Documentation Use
- RFC5492 Capabilities Advertise with BGP-4
- RFC5561 LDP Capabilities
- RFC5668 4-Octet AS Specific BGP Extended Community
- RFC6241 Network Configuration Protocol (NETCONF)
- RFC6310 Pseudowire (PW) Operations, Administration, and Maintenance (OAM) Message Mapping
- RFC6793 BGP Support for Four-Octet Autonomous System (AS) Number Space
- RFC7432 EVPN VPWS/ VPLS
- RFC7737 Label Switched Route (LSP) Ping and Traceroute Reply Mode Simplification
- RFC7911 Advertisement of Multiple Paths in BGP
- RFC8214 Virtual Private Wire Service Support in Ethernet VPN
- SR-MPLS TI-LFA Topology Independent Fast Reroute using Segment Routing draft-ietf-rtgwg-segment-routing-ti-lfa-03
- SRv6 Micro Segments draft-filsfils-spring-net-pgm-extension-srv5-usid-04
- Network Management
- Alarm Management and Monitoring Configuration
- Event and Alarm Notification/Generation Comprehensive Management
- Via CLI Management
- Via Netconf/YANG Models
- gRPC-based Streaming telemetry
- IPv4 and IPv6 Management Support
- IPv4 Management ACL (in-band)
- IPv6 Management ACL (in-band)
- RADIUS, AAA
- RFC 2131 DHCP Client
- RFC 3046 DHCP Relay
- RFC 5905 NTP Client
- Secure File Transfer Protocol (SFTP)
- Secure Shell (SSHv2)
- RFC 8572 Secure Zero-Touch Provisioning (SZTP)
- Software upgrade via FTP, SFTP
- Syslog Accounting
- TACACS + AAA
- Web GUI

Physical Characteristics

Dimensions

- 17.5" (W) x 9.9" (D) x 1.75" (H)
- 444mm (W) x 252mm (D) x 44mm (H)

Weight

- AC variant: 13.2 lbs; 6.2 kg
- DC variant: 13.2 lbs; 6 kg

Technical Information continued

Power Requirements

- DC input: -48 Vdc (nominal)
- AC input: 100Vac, 240 Vac (nominal)

Standards Compliance

Emissions

- CISPR 22 Class A
- CISPR 32 Class A
- EN 300 386
- EN 55032
- FCC Part 15 Class A GR-1089 Issue 6
- Industry Canada ICES-003 Class A VCCI Class A
- VCCI Class A

Environmental

- RoHS2 Directive (2011/65/EU)
- WEEE 2002/96/EC

Operating Temperature

- -40°F to +149°F (-40°C to +65°C)

Storage Temperature

- -40°F to +158°F (-40°C to +70°C)

Humidity

- Non-condensing 5% to 90%

Immunity (EMC)

- GR-1089 Issue 6
- CISPR 24

Power

- ETSI EN 300 132-2
- ETSI EN 300 132-3

Safety

- ANSI/UL 60950-1 2nd edition 2007
- CAN/CSA C22.2 No. 60950-1-07
- EN 60950-1
- IEC 60825-1 2nd edition (2007)
- IEC 60825-2 3rd edition (2004)

Power Consumption

- 135W typical
- 175W max

Service Security

- Broadcast Containment Egress Port Restriction
- Hardware-based DOS Attack Prevention Layer 2, 3, 4 Protocol Filtering
- User Access Rights Local user authorization

*Future: 1H21

Ordering information

Part Number	Description
170-5130-900	5130, (12)25/10/1GBE SFP28, (2)100 GBE QSFP28, EXT. TEMP, DUAL DC POWER
170-5130-901	5130, (12)25/10/1GBE SFP28, (2)100 GBE QSFP28, EXT. TEMP, DUAL AC POWER

Required OS Base System Perpetual Software Licenses

S75-LIC-5130EO-P	SAOS BASE OS, ETHERNET & OAM, FLEXE, SOFTWARE LICENSE FOR 5130, PERPETUAL
S75-LIC-5130EVPN-P	SAOS EVPN SOFTWARE LICENSE FOR 5130, PERPETUAL

Optional OS Applications

S75-LIC-5130MPLS-P	SAOS ROUTING AND MPLS SOFTWARE LICENSE FOR 5130, PERPETUAL
S75-LIC-5130SYNC-P	SAOS SYNCHRONIZATION SOFTWARE LICENSE FOR 5130, PERPETUAL
S75-LIC-5130SEC-P	SAOS SECURITY SOFTWARE LICENSE FOR 5130, PERPETUAL
S75-LIC-5130100G-P	SAOS 100G SOFTWARE LICENSE FOR 5130, PERPETUAL

Ciena may make changes at any time to the products or specifications contained herein without notice. Ciena and the Ciena Logo are trademarks or registered trademarks of Ciena Corporation in the U.S. and other countries. A complete list of Ciena's trademarks is available at www.ciena.com. Third-party trademarks are the property of their respective owners and do not imply a partnership between Ciena and any other company. Copyright © 2023 Ciena® Corporation. All rights reserved. DS359 10.2023

Visit the Ciena Community
Get answers to your questions

Find out more